

Operation of the overrun braking system.

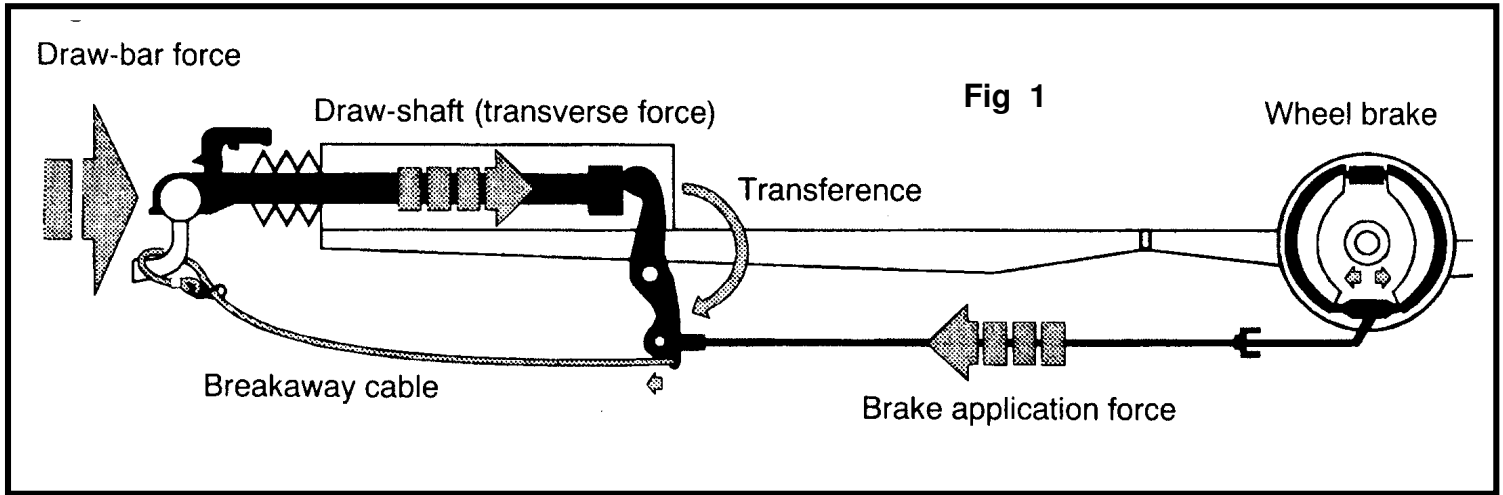

The overrun device can be described as the control device of the overrun brake system. A draw-bar force is produced at the coupling point by reducing the speed of the towing vehicle. After the threshold level has been passed, the draw shaft is pushed in, thus actuating the overrun lever, the wheel brakes (1 & 2) are then applied via the expanding clutch (3) (Fig 2)

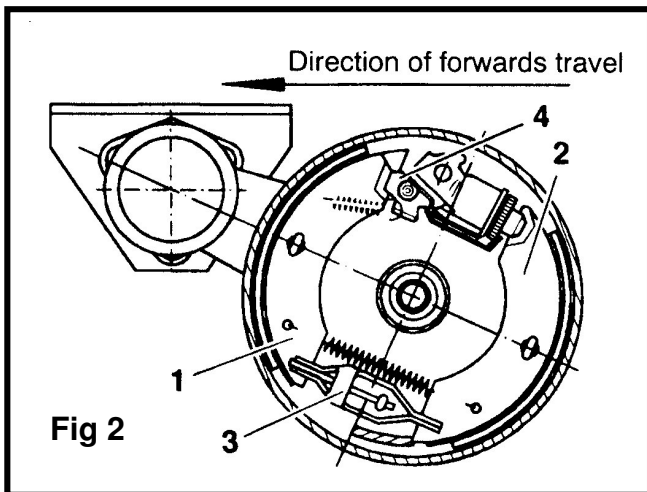

Reversing.

When reversing, the towing vehicle pushes in the draw shaft of the overrun device. The brake shoes (1,2) are pressed against the brake drum via brake linkage, Bowden cable and expander clutch (3). The brake drum turns backwards, taking the trailing shoe (1) with it. The transmission lever (4) swings back and allows the draw shaft to complete it's full travel. The braking effect is virtually cancelled out and the wheels can revolve freely in reverse (Fig 3).

Parking.

On the spring cylinder version, engage the handbrake lever right up to the last tooth (90°). On the gas strut handbrake version, pull the handbrake lever over centre. The brake shoes (1 and 2) are pressed against the brake drum by the brake linkage etc. and this applies the trailer brakes.

When the caravan/trailer has been reversed, the brake drum will also rotate backwards. The trailing brake shoe (1) is taken with it and moves the transmission lever (4) back. This lever then pushes the adjuster assembly (5) which in turn pushes the leading brake shoe (2) against the stop (6). The caravan/trailer is then braked.

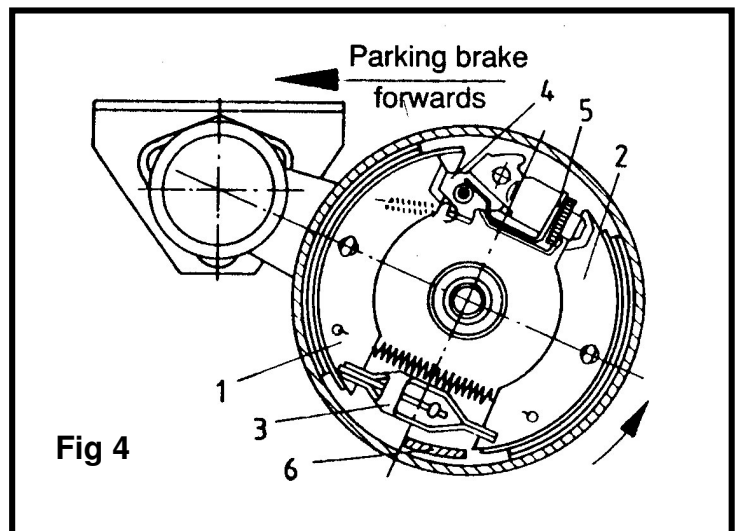
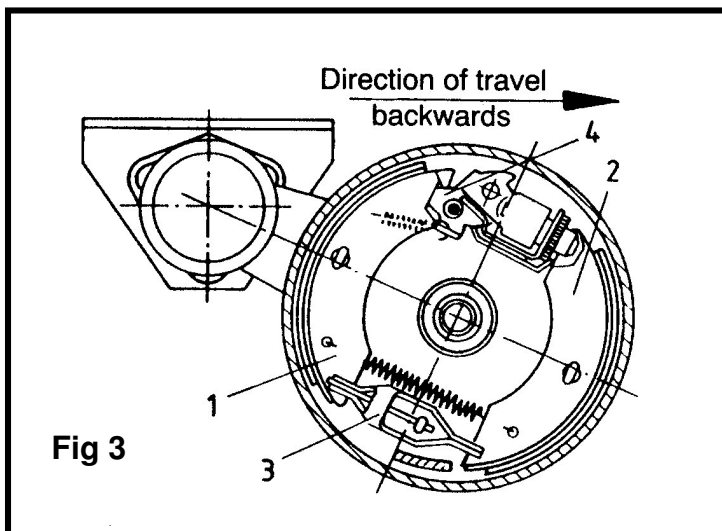
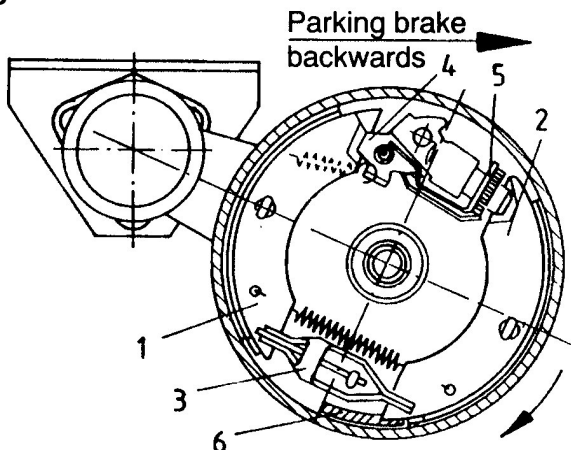
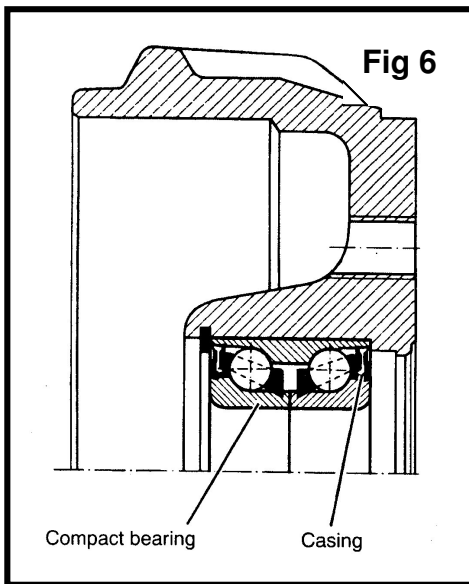

Fig 5



It must be noted that when the handbrake is applied, the vehicle may roll approximately 25 cm (10 inches) backwards before the parking brake force is used to it's fullest extent.

Wheel Bearing



The wheel bearing is a double-row inclined ball bearing. It has the following advantages over normal bearings.

- No adjustments necessary.
- Easy to maintain (lubricated for life and sealed)
- Protected against dirt ingress (sealed unit)
- Less sensitive to seizure than a taper roller bearing.



The bearing must not be pressed out of the drum as this may damage the bearing and brake drum.

Adjusting the wheel brakes.

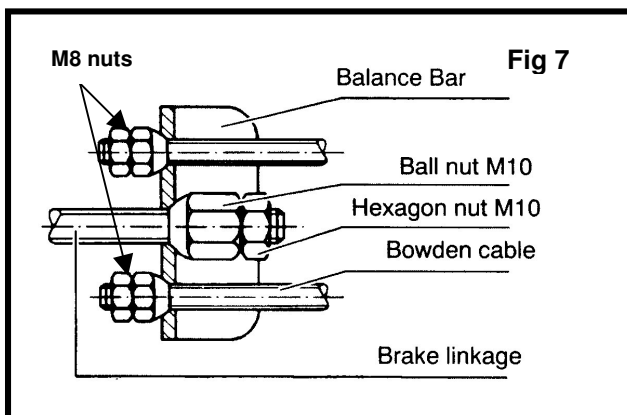

Before adjusting the wheel brakes always rotate the wheel(s) in the forward direction

- Lift the caravan/trailer using a suitable jack.
- Ensure the coupling head and overrun shaft are fully extended.
- Release the handbrake completely.
- Release the brake linkage from the balance bar(Fig 7)
- On newer models the M8 nuts are quick fit nipples.
- Check the free play in the wheel brake.

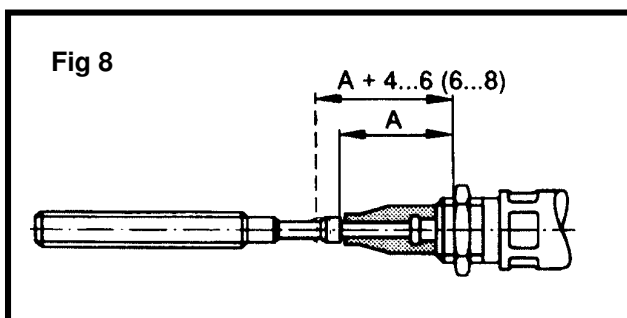

The free play should be as uniform as possible for 2 or 4 wheel brakes respectively.

Nominal : 4 - 6mm on single axles.

6 - 8mm on tandem axles.

Measured on the inner cable where attached to the axle abutment bracket .

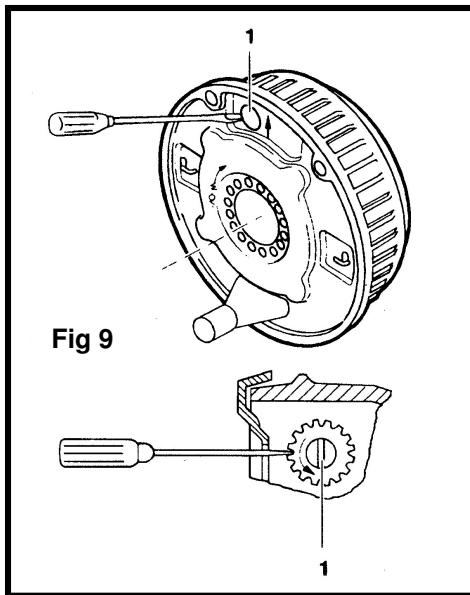

- Only ever set or adjust the wheel brake by means of the adjuster screw (1)(Fig 9). Adjust in the direction of the arrow, and release against the direction of the arrow.
- Reconnect the brake linkage to the balance bar, and apply the handbrake hard several times, to allow the braking adjustment to settle.

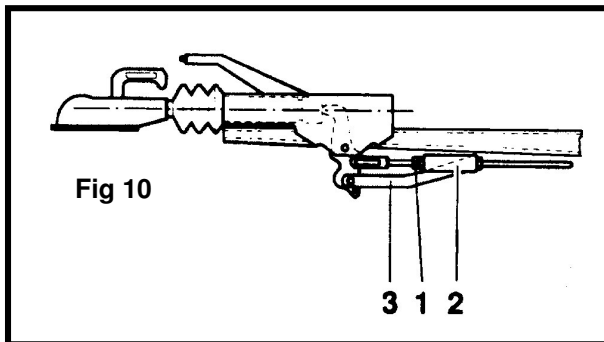

- On the spring cylinder type (2), adjust the locking nuts M10 (1)(Fig 10) to allow 1mm of free play between the nut and the spring cylinder. The cylinder should be able to rotate freely but not slide on the brakerod.
N.B On some chassis the locking nuts are replaced with a single Nyloc nut.

Check the setting

- Apply the handbrake lever up to the first or second tooth, and check that there is equal braking resistance on each wheel.
- On the gas strut version the handbrake lever has to be held on the first tooth manually.



When adjusting the wheel brake, only turn the wheels in a forward direction so that reverse mode is not actuated.

Servicing the wheel brakes.

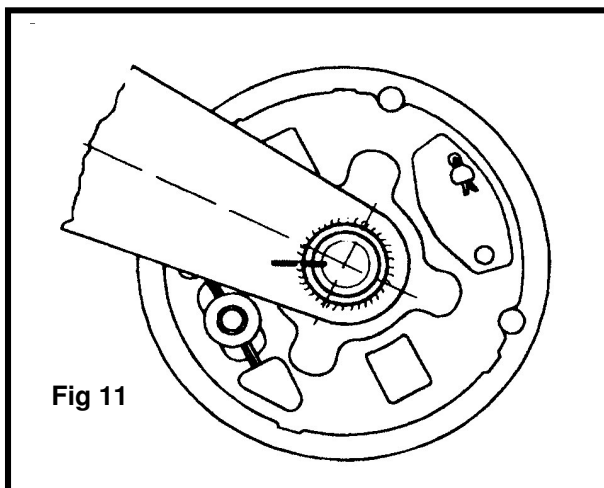

Dismantling the brake drum.

- Remove the wheel and tyre.
- Mark the position of the plastic cap on the swing arm with a felt tip pen so that any movement on the stub axle can be detected (Fig 11)



If the stub axle or back nut are moved this will alter the toe-in and camber . Should such movement take place the axle should be removed and returned to AL-KO to be realigned.

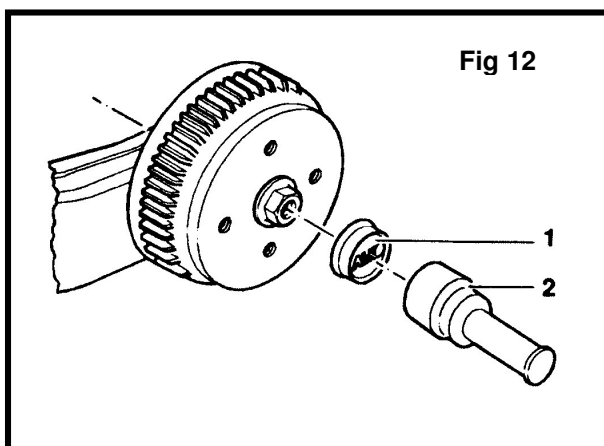

- Remove dust cap with Former Tool (603751).
- Unscrew the flange nut. **Always use a new nut when refitting.**
- Before fitting new nut apply a small amount of mineral grease (800052) to the stub axle thread.
- Release the handbrake and remove the drum.
- Replace worn or corroded brake drums.



Note the torque setting (290Nm +/- 10Nm).

Brake drums must not be reskimmed.

Visual checks.

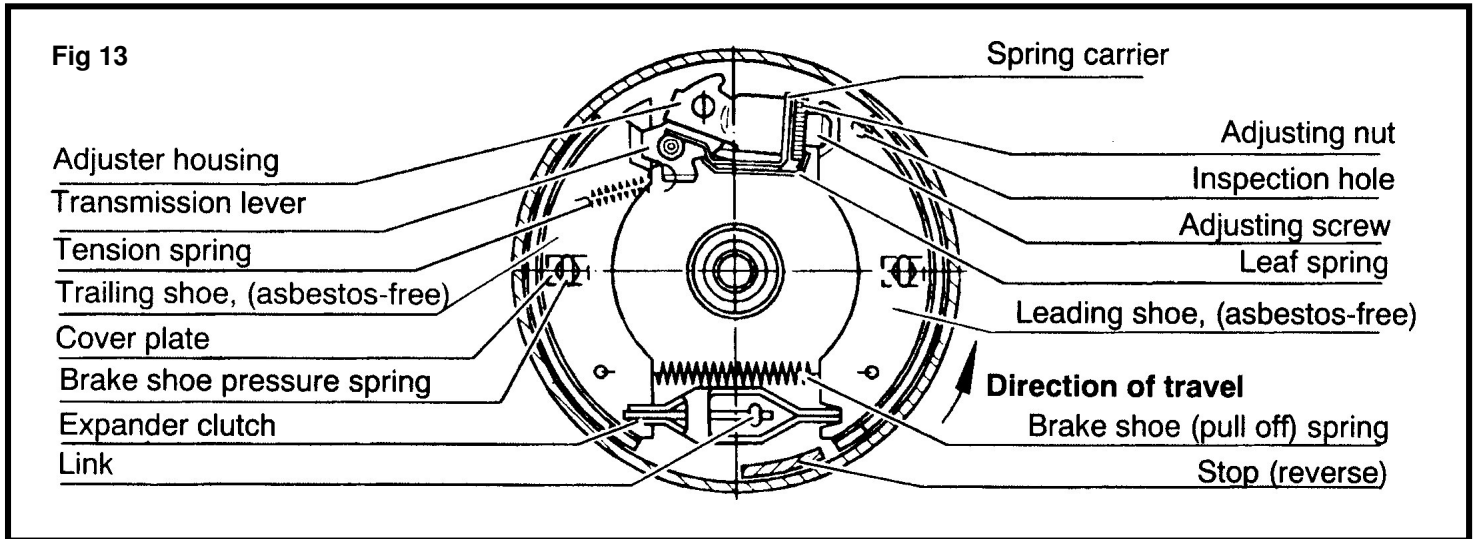

Check the condition of the brake shoes.

The wear on the shoes is greatest where the inspection hole is located on the backplate. The leading shoe usually wears faster than the trailing shoe.



Always replace brake shoes as a pair.

- Check that the expander clutch, adjuster nut and transmission lever are lubricated and running smoothly (use Molybdenum Disulphide grease).
- Check the tension on the leaf spring and that the adjusting nut is engaged onto the brakeshoe.
- Check the pressure of the brakeshoe retaining springs.

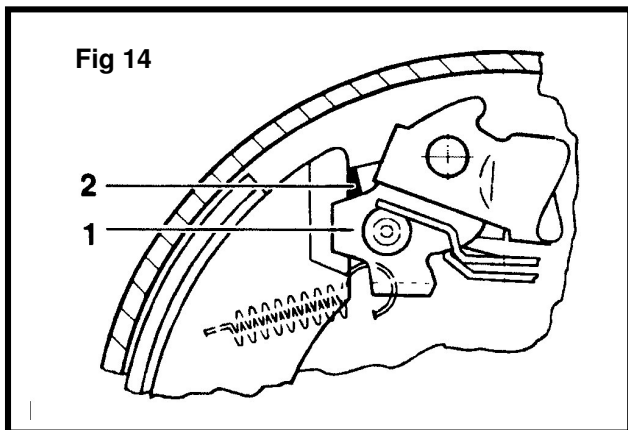

- Transmission lever (1) must abut the adjuster housing stop (2).

- If any parts are to be removed from the wheel brake the Bowden cable must be unhooked from the expander clutch.
- Replace brakeshoes where linings are less than 2mm thickness.
- If replacing pressure springs also replace cover plates.
- On type 1637, the left and right shoes are different. The embossed markings (see arrows Fig 15) must be followed.



If the shoes are fitted to the wrong side the brake will not function.

- 2051 and 2361 brake shoes are **NOT** handed.

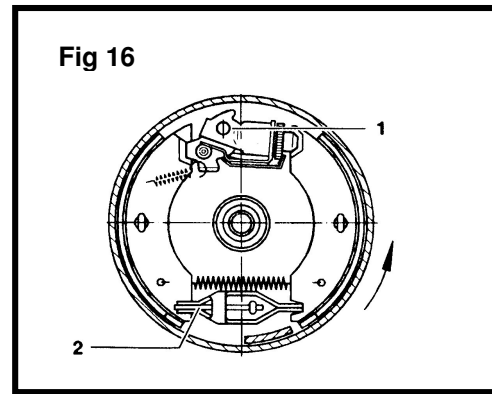
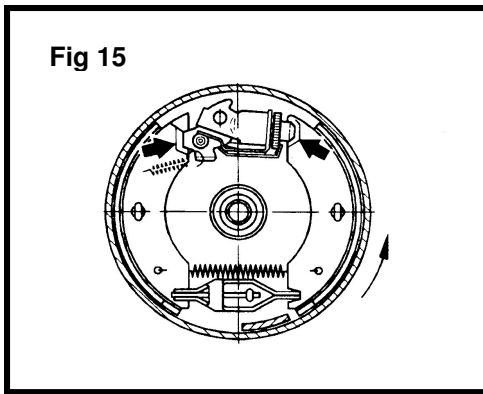

Expanding clutch.

- Lubricate expander pivot points.
- Replace corroded expanders.
- **N.B** Note the correct position for fitting:
Expander lever pivot arm (2) to transmission lever pivot bolt (1). These points **must always** be on the same side (Fig 16).

Return springs.

- Replace relaxed or damaged return (pull off) springs.

Transmission lever.

- Lubricate pivot points.
- Replace corroded or damaged levers and pivot bolts.
- If the lever does not abut the adjuster housing stop, replace extension spring (Fig 14).

Adjusting assembly.

- Lubricate adjusting nuts.
- Unscrew the adjuster screw and lubricate the thread.
- Replace corroded or damaged screws or nuts.

Leaf springs (adjuster housing).

- Replace corroded or relaxed leaf springs.

N.B The adjuster screw, nut and leaf spring are only supplied as a complete assembly.

Part No.s are as follows:

1637 Brakes - 387706
 2051 Brakes - 387323
 2361 Brakes - 387323



All friction points on the wheel brake must be lubricated with Molybdenum Disulphide Grease (AL-KO Part No. 800098)



Scanvogn Australia
 1, 2-6 Bonnal Rd
 Erina, NSW 2250
 02 4367 0026
 info@scanvogn.com.au
 MD058440, ABN:66609680668